



## Application - Distribution and Logistics

### Key Problems

Warehouse logistics and material handling system solutions require planned and reactive maintenance programs, often in elevated areas.

The movement of goods in a distribution or manufacturing operation requires sophisticated automation systems. The higher the volume of movement the greater level of complexity required.

Material flow solutions, using pallet or case conveyors, AGVs and monorails are a highly effective means of moving goods between work areas. They offer real time tracking of goods and added value tasks; for example, wrapping, weighing and the sorting of goods.

Maintenance is key to an efficient process; many areas are awkward and therefore difficult to reach; each task often being different from the last. Working at height must be accomplished safely and traditionally outsourced scaffolding companies and fixed aluminium tower systems have been deployed. Outsourced scaffolding labour is expensive and not available 24/7, aluminium frame systems are cumbersome, inflexible, difficult to transport and will not adjust to fit into awkward areas.

### The Solution



Using a LOBO System solution can dramatically improve logistics system operation by reducing scaffolding labour costs, which in turn improves service levels and increases operator productivity.

The LOBO System can be assembled quickly, easily and safely around, through or above conveyors and restricted access areas – by your own in-house maintenance crew.

[www.lobosystems.com](http://www.lobosystems.com)

#### Conformities

EU: BS EN1004:2004 BS 1139 parts 3 & 4,  
USA: OSHA Compliant, ANSI A10.8, 29 CFR Part 1920 (General Industry)  
Canada: CSA Z797-09 and 269.2 (M87 and -16)  
Australia: AS/NZS 1576.1:2010 and AS/NZS 1576.3:2015 Tower





This means out-sourced scaffolding labour costs can be reduced without compromising safety. Areas previously considered difficult to get to can now be accessed with ease for maintenance and cleaning purposes. In addition, it is available 24/7 therefore puts you in control of what and when you schedule your maintenance tasks.

### Product Benefits

a) LOBO is scalable, adaptable and adjustable to meet your on-going and changing requirements. Simply add more components or alter your existing configuration to satisfy the demands of the next task. Protect your initial investment with a product that will meet all your access needs safely!

b) LOBO is a rigid and stable product, which meets or exceeds current safety regulations. Handrails can be fitted in seconds, at any point in the erection process.



c) LOBO's steel structure ensures many years of product life cycle and a system that will not shake or rattle. The system also includes a slider lifting beam kit and a Towerstore storage unit.

d) LOBO's modular approach means components fully integrate and can be hand carried. Fully constructed systems can also be made mobile by the addition of wheels.

### Cost Benefits

Experience shows that deploying the LOBO system reduces the costs associated with hiring scaffolding and constructing bespoke access systems. By reducing your reliance on out-sourced scaffolding and engineering companies cost savings will be achieved – easily in a 12-month period.

[www.lobosystems.com](http://www.lobosystems.com)

#### Conformities

EU: BS EN1004:2004 BS 1139 parts 3 & 4,  
USA: OSHA Compliant, ANSI A10.8, 29 CFR Part 1920 (General Industry)  
Canada: CSA Z797-09 and 269.2 (M87 and -16)  
Australia: AS/NZS 1576.1:2010 and AS/NZS 1576.3:2015 Tower





With this quantifiable reduction in costs comes the added savings associated with reduced down time and greater productivity from your maintenance department

Available 24/7, quick to erect – and above all safe – it is immediately adjustable for your next job with no staff waiting time while new fixed-frame structures are built.

Re-configurable, again and again, this product comes with no disposal costs and minimal replacement and on-going training costs.

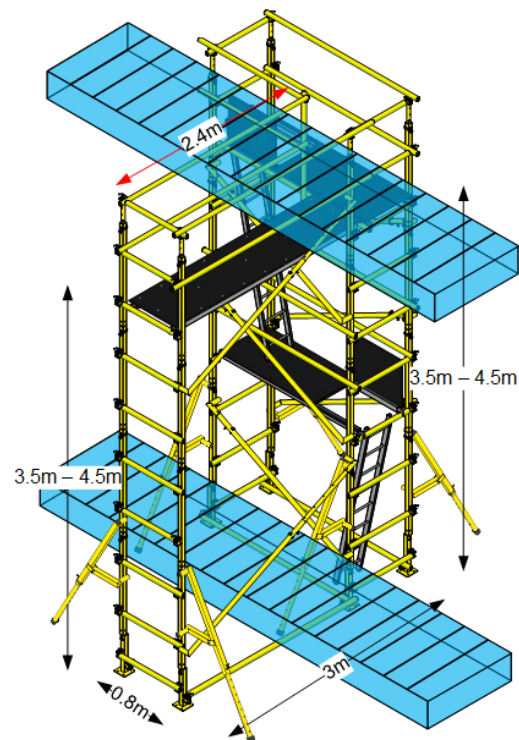

[www.lobosystems.com](http://www.lobosystems.com)

**Conformities**

EU: BS EN1004:2004 BS 1139 parts 3 & 4,  
USA: OSHA Compliant, ANSI A10.8, 29 CFR Part 1920 (General Industry)  
Canada: CSA Z797-09 and 269.2 (M87 and -16)  
Australia: AS/NZS 1576.1:2010 and AS/NZS 1576.3:2015 Tower

